

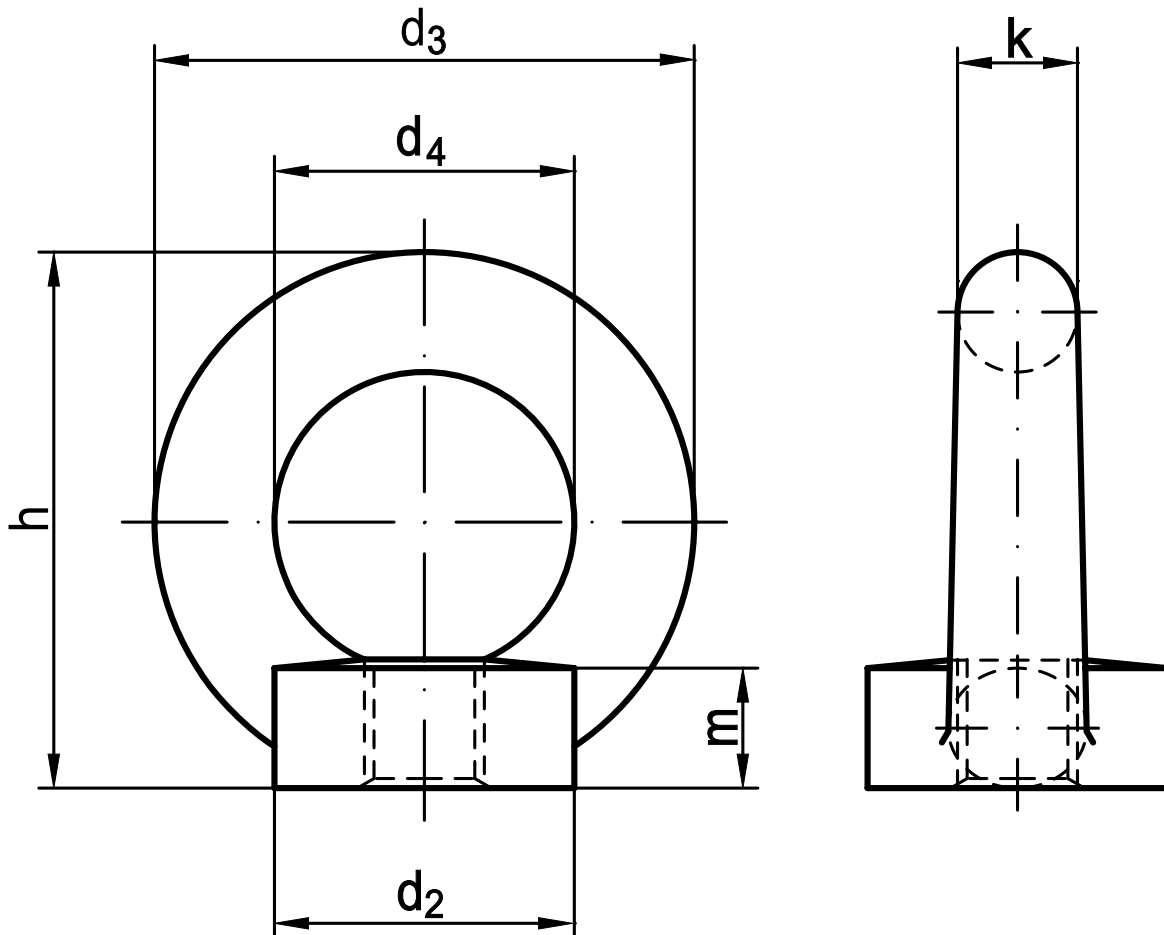

Sonderformen

# DIN 582

## Ringmuttern



\* Abmessung nicht genormt, Maße der nächst größeren Abmessung

| Maße  | M 6* | M 8 | M 10 | M 12 | M 14* | M 16 | M 18* | M 20 | M 22* |
|-------|------|-----|------|------|-------|------|-------|------|-------|
| $d_2$ | 17   | 20  | 25   | 30   | 35    | 35   | 40    | 40   | 45    |
| $d_3$ | 28   | 36  | 45   | 54   | 63    | 63   | 72    | 72   | 81    |
| $d_4$ | 16   | 20  | 25   | 30   | 35    | 35   | 40    | 40   | 45    |
| $m$   | 8,5  | 8,5 | 10   | 11   | 13    | 13   | 16    | 16   | 18    |
| $h$   | 31   | 36  | 45   | 53   | 62    | 62   | 71    | 71   | 80,5  |
| $k$   | 6    | 8   | 10   | 12   | 14    | 14   | 16    | 16   | 18    |

| Maße  | M 24 | M 27* | M 30 | M 33* | M 36 | M 42 | M 48 | M 56 |
|-------|------|-------|------|-------|------|------|------|------|
| $d_2$ | 50   | 50    | 65   | 65    | 75   | 85   | 100  | 110  |
| $d_3$ | 90   | 90    | 108  | 108   | 126  | 144  | 166  | 184  |
| $d_4$ | 50   | 50    | 60   | 60    | 70   | 80   | 90   | 100  |
| $m$   | 20   | 20    | 25   | 25    | 30   | 35   | 40   | 45   |
| $h$   | 90   | 90    | 109  | 109   | 128  | 147  | 168  | 187  |
| $k$   | 20   | 20    | 24   | 24    | 28   | 32   | 38   | 42   |