

# DIN 917

Sechskant-Hutmuttern, niedrige Form

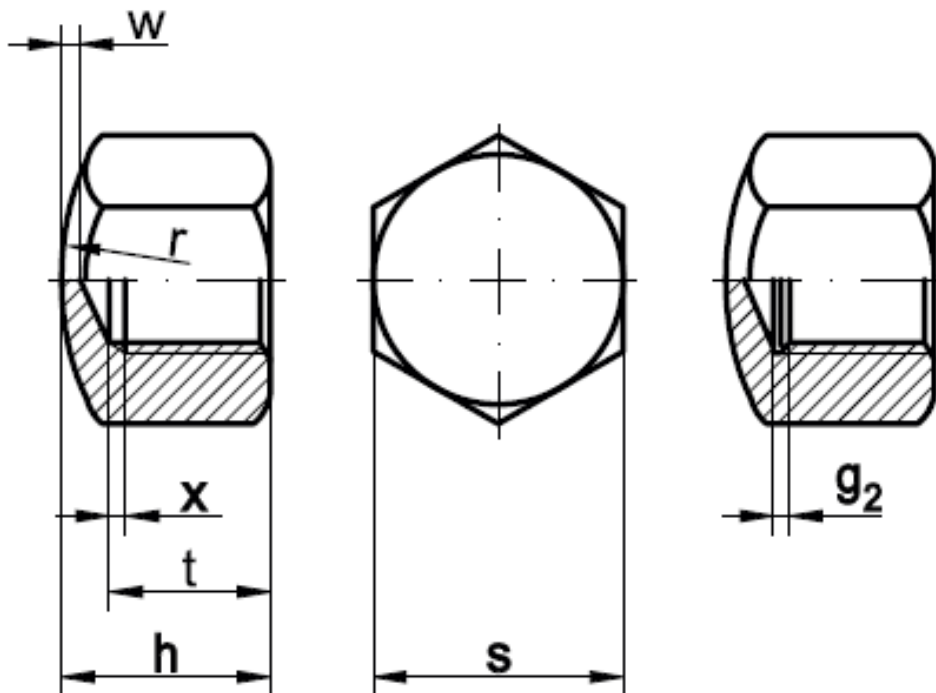

ab M 10 Freistich nach DIN 76-1  
(Form D kurz) mit dem Maß  $g_2$  max.

| Maße                  | M 4  | M 5  | M 6  | M 8  | M 10  | M 12  |
|-----------------------|------|------|------|------|-------|-------|
| $x_{max.} / g_2 max.$ | 1,05 | 1,2  | 1,5  | 1,87 | 2,25  | 6,4   |
| h                     | 5,5  | 7    | 9    | 12   | 14    | 16    |
| r                     | 8    | 10   | 12   | 15   | 20    | 25    |
| $s_{ISO/DIN}$         | 7    | 8    | 10   | 13   | 16/17 | 18/19 |
| $t_{min.}$            | 4,16 | 4,96 | 6,71 | 9,21 | 10,65 | 13,15 |
| $w_{min.}$            | 1    | 1    | 1,5  | 2    | 2     | 2     |

| Maße                  | M 14  | M 16  | M 20  | M 24  | M 30  | M 36 |
|-----------------------|-------|-------|-------|-------|-------|------|
| $x_{max.} / g_2 max.$ | 7,3   | 7,3   | 9,3   | 10,7  | 12,7  | 14   |
| h                     | 18    | 20    | 25    | 30    | 34    | 44   |
| r                     | 28    | 30    | 35    | 40    | 60    | 70   |
| $s_{ISO/DIN}$         | 21/22 | 24    | 30    | 36    | 46    | 55   |
| $t_{min.}$            | 14,65 | 16,65 | 20,58 | 23,58 | 27,58 | 35,5 |
| $w_{min.}$            | 2     | 2     | 2,5   | 3     | 3     | 4    |

